

***THIS DOCUMENT IS FOR MAINTENANCE
PURPOSES ONLY AND IS NOT
RECOMMENDED FOR NEW DESIGNS***

MV5087

DTMF GENERATOR

The MV5087 is fabricated using ISO-CMOS high density technology and offers low power and wide voltage operation. An inexpensive 3.58MHz TV crystal completes the reference oscillator. From this frequency are derived 8 different sinusoidal frequencies which, when appropriately mixed, provide Dual-Tone Multi-Frequency (DTMF) tones.

Inputs are compatible with either a standard 2-of-8 or a single contact (form A) keyboard. The keyboard entries determine the correct division of the reference frequency by the row and column counters.

D-to-A conversion, using R-2R ladder networks, results in an staircase approximation of a sinewave with low total distortion.

Frequency and amplitude stability over operating voltage and temperature range are maintained within industry specifications.

FEATURES

- Pin-for-Pin Replacement for MK5087
- Low Standby Power
- Minimum External Parts Count
- 3.5V to 10V Operation
- 2-of-8 Keyboard or Calculator-Type Single Contact (Form A) Keyboard Input
- On-Chip Regulation of Output Tone
- Mute and Transmitter Drivers On-Chip
- High Accuracy Tones Provided by 3.58MHz Crystal Oscillator
- Pin-Selectable Inhibit of Single Tone Generation

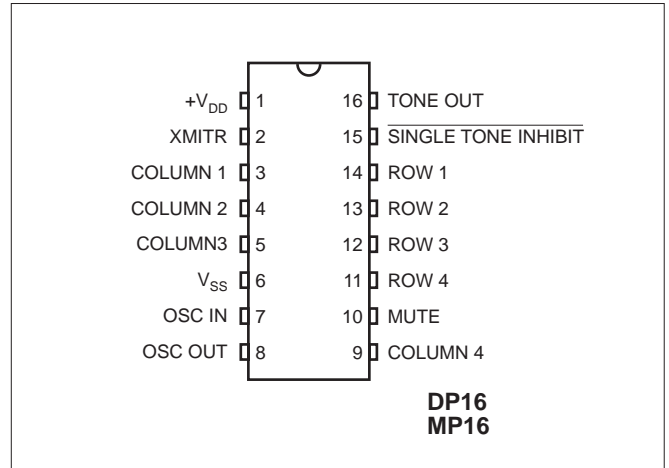

Figure 1: Pin connections - top view

APPLICATIONS

DTMF Signalling for

- Telephone Sets
- Mobile Radio
- Remote Control
- Point-of-Sale and Banking Terminals
- Process Control

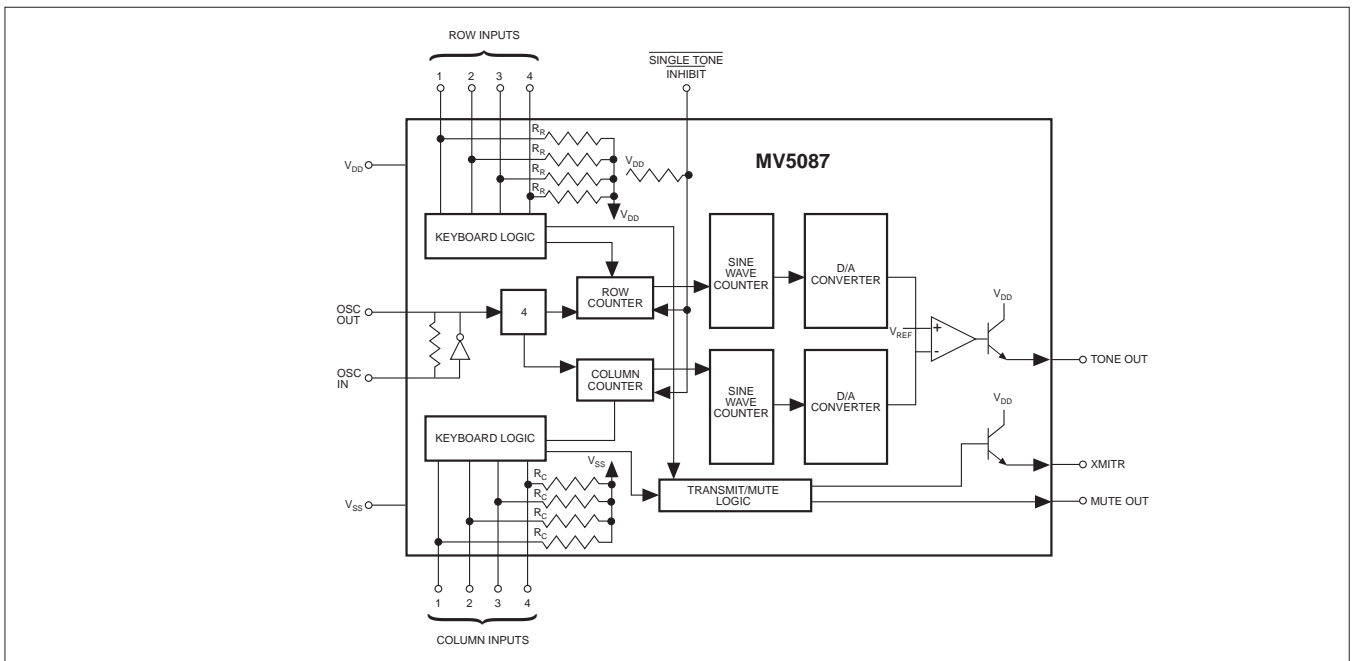

Figure 2: Functional block diagram

MV5087

ABSOLUTE MAXIMUM RATINGS

	Min.	Max.		Min.	Max.
$V_{DD} - V_{SS}$ Voltage on any pin Current on any pin Operating temperature Storage temperature	-0.3V $V_{SS} - 0.3V$ -40°C -65°C	10.5V $V_{DD} + 0.3V$ 10 mA +85°C +150°C	Power dissipation Derate 16 mW/°C above 75°C (All leads soldered to PCB)		850 mW

DC ELECTRICAL CHARACTERISTICS

Test conditions (unless otherwise stated):

$T_{amb} = +25^{\circ}C$, $V_{DD} = 3.5V$ to $10V$

Characteristics		Symbol	Min.	Typ.	Max.	Units			
SUPPLY	Operating Supply Voltage	V_{DD}	3.5		10	V	Ref. to V_{SS}		
	Standby Supply Current	I_{DDs}		0.2	100	uA	$V_{DD} = 3.5V$	No Key Depressed	
	Operating Supply Current	I_{DD}		0.5	200	uA	$V_{DD} = 10V$	All outputs Unloaded	
INPUTS	SINGLE TONE INHIBIT	Input High Voltage	V_{IH}	$0.7V_{DD}$		V_{DD}	V		
		Input Low Voltage	V_{IL}	0		$0.3V_{DD}$	V		
	ROW 1-4	Input Resistance	R_{IN}		60		K Ω		
		Input High Voltage	V_{IH}	$0.9V_{DD}$			V		
	COLUMN 1-4	Input Low Voltage	V_{IL}			$0.3V_{DD}$	V		
		Input High Voltage	V_{IH}	$0.7V_{DD}$			V		
		Input Low Voltage	V_{IL}			$0.1V_{DD}$	V		
		XMTR	Source Current	I_{OH}	-15	-25		mA	$V_{DD} = 3.5V, V_{OH} = 2.5V$
Leakage Current	I_{OZ}			-50	-100		mA	$V_{DD} = 10V, V_{OH} = 8V$	Keyboard Entry
OUTPUTS	MUTE	Sink Current	I_{OL}	0.5			mA	$V_{DD} = 3.5V, V_{OL} = 0.5V$	No Keyboard Entry
		Source Current	I_{OH}	1.0			mA	$V_{DD} = 10V, V_{OL} = 0.5V$	Keyboard Entry
		Sink Current	I_{OL}	-0.5			mA	$V_{DD} = 3.5V, V_{OH} = 3.0V$	Keyboard Entry
		Source Current	I_{OH}	-1.0			mA	$V_{DD} = 10V, V_{OH} = 9.5V$	Keyboard Entry

AC ELECTRICAL CHARACTERISTICS

Test conditions (unless otherwise stated):

$T_{amb} = +25^{\circ}C$, $V_{DD} = 3.5V$ to $10V$

Characteristics		Symbol	Min.	Typ.	Max.	Units		
TONE OUT	Row Tone Output Voltage	V_{OR}	320	400	500	mV _{RMS}	Single Tone $R_L = 1K\Omega$	
	Column Tone Output Voltage	V_{OC}	400	500	630	mV _{RMS}		
	External Load Impedance	R_L	700			Ω	$V_{DD} = 3.5V$	
			300			Ω	$V_{DD} = 10V$	
OUTPUT DISTORTION					-20	dB	Total out-of-band power relative to sum of row and column fundamental power	
PRE EMPHASIS, High Band			1		3	dB		
Tone Output Rise Time		t_r		3	5	ms		

PIN FUNCTIONS

PIN	NAME	DESCRIPTION
	V _{DD}	Positive Power Supply
2	XMITR	Emitter output of a bipolar transistor whose collector is connected to V _{DD} . With no keyboard input this output remains at V _{DD} and a keyboard input changes the output to a high impedance state. The state of Single Tone Inhibit input has no effect on XMITR output.
3,4,5,9	Column 1-4	These inputs are held at V _{SS} by resistors R _C and sense a valid logic level (approx 1/2 V _{DD}) when tied to a ROW input.
	V _{SS}	Negative Power Supply (OV)
7,8	OSC In, OSC Out	On-chip inverter completes the oscillator when a 3,579545 MHz crystal is connected to these pins. OSC In is the inverter input and OSC Out is the output.
10	Mute	This CMOS Output switches to V _{SS} with no keyboard input and to V _{DD} with a keyboard input. This output is unaffected by the state of Single Tone Inhibit.
11,12,13,14	Row 1-4	These inputs are held at V _{DD} by resistors R _R and sense a valid logic level (Approx 1/2 V _{DD}) when tied to a column input.
15	Single Tone Inhibit	This input has a pull-up resistor to V _{DD} and when left unconnected or tied to V _{DD} , single or dual tones may be generated. When V _{SS} is applied dual tones only are generated and no input combinations will cause generation of a single tone.
16	Tone Out	Emitter output of a bipolar NPN transistor whose collector is tied to V _{DD} . Input to this transistor is from an op-amp which mixes, and regulates the output level of, the row and column tones.

ROW AND COLUMN INPUTS

These inputs are compatible with the standard 2-of-8 keyboard, single contact (form A) keyboard and electronic input. Figures 3 and 4 show these input configurations, and Fig. 5 shows the internal structure of these inputs.

When operating with a keyboard, dual tones are generated when any single button is pushed. Single tones are generated when more than one button is pushed in any row

or column. No tones are generated when diagonally positioned buttons are simultaneously pressed.

An electronic input to a single column generates that single column tone. Inputs to multiple columns generates no tone. An electronic input to a single row generates no tone and a single row tone may be generated only by activating 2 columns and the desired row.

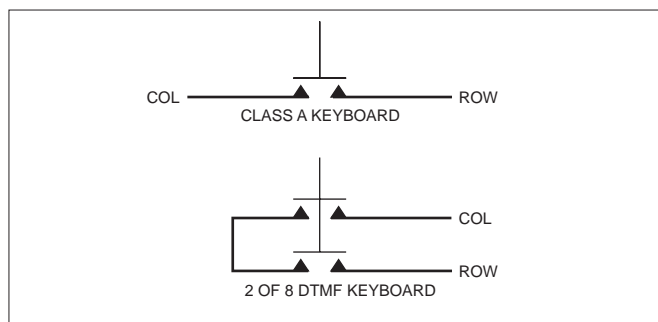

Figure 3: Keyboard configuration

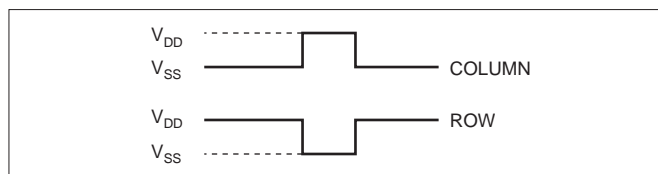

Figure 4: Electronic input

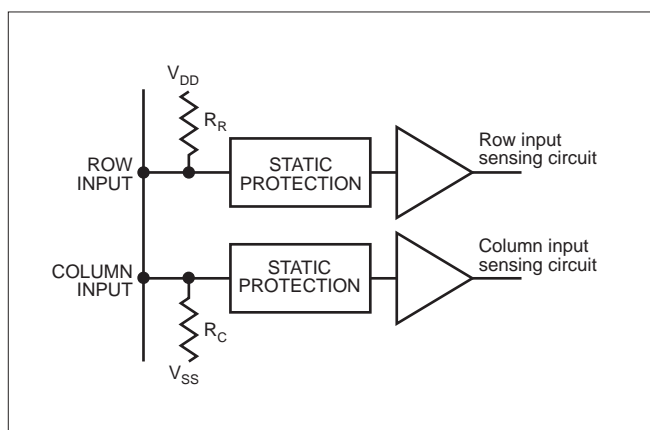

Figure 5: Row and column inputs

OUTPUT FREQUENCY

Table 1 shows the output frequency deviation from the standard DTMF frequencies when a 3.58MHz crystal is used as the reference.

The row and column output waveforms are digitally synthesised using R-2R D-to-A converters (see Fig.6), resulting in a 'staircase' approximation to a sinewave. An opamp mixes these tones to produce a dual-tone waveform. Single tone distortion is typically better than 7% and all distortion components of the mixed dual-tone should be 30dB relative to the strongest fundamental (column tone).

	Standard DTMF (Hz)	Tone Output Frequency Using 3.5795545 MHz Crystal	% Deviation from Standard	
Row	f ₁ 697	701.3	+0.62	Low Group
	f ₂ 770	771.4	+0.19	
	f ₃ 852	857.2	+0.61	
	f ₄ 941	935.1	-0.63	
	f ₅ 1209	1215.9	+0.57	
Column	f ₆ 1336	1331.7	-0.32	High Group
	f ₇ 1477	1471.9	-0.35	
	f ₈ 1633	1645.0	+0.73	

Table 1: Output frequency deviation

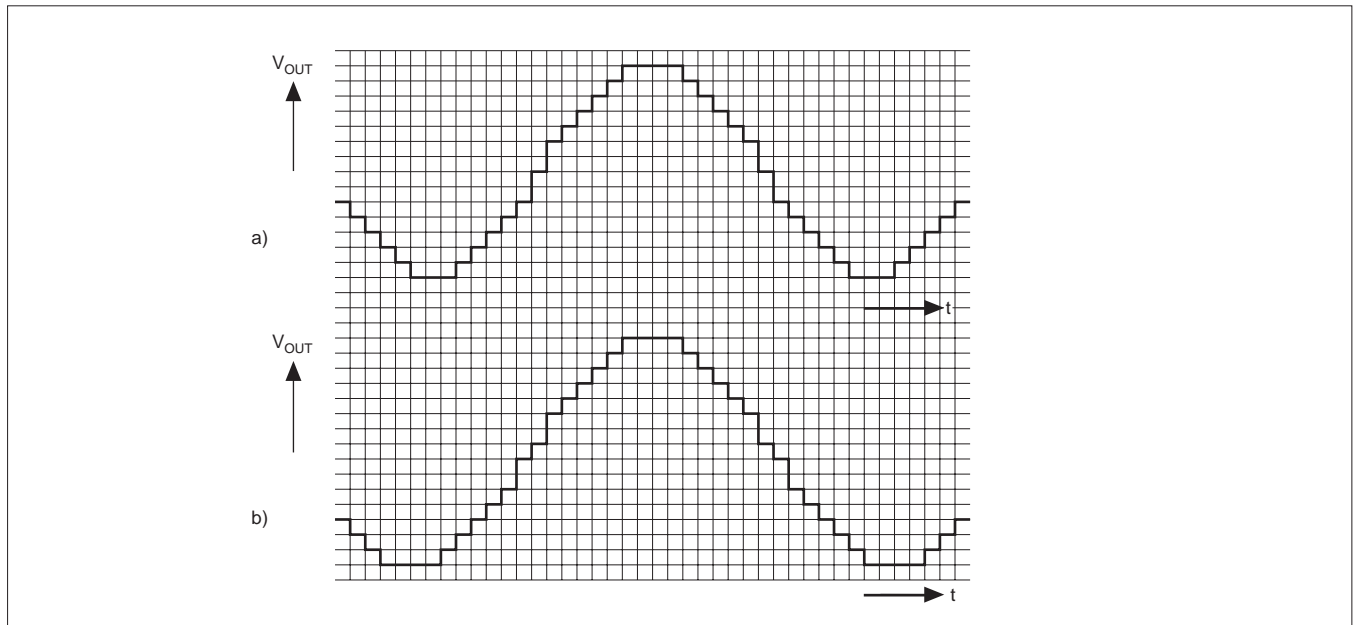

Figure 6: Typical sinewave output (a) Row tones (b) Column tones

DISTORTION MEASUREMENTS

THD for the single tone is defined by:

$$100 \left(\frac{\sqrt{V_{2f}^2 + V_{3f}^2 + V_{4f}^2 + \dots + V_{nf}^2}}{V_{\text{fundamental}}} \right) \%$$

Where V_{2f} --- V_{nf} are the Fourier components of the waveform.

THD for the dual tone is defined by:

$$100 \left(\frac{\sqrt{V_{2R}^2 + V_{3R}^2 + V_{nR}^2 + V_{2C}^2 + V_{3C}^2 + \dots + V_{nC}^2 + V_{\text{IMD}}^2}}{\sqrt{V_{\text{ROW}}^2 + V_{\text{COL}}^2}} \right)$$

- where V_{ROW} is the row fundamental amplitude
- V_{COL} is the column fundamental amplitude
- V_{2R}—V_{nR} are the Fourier component amplitudes of the row frequencies
- V_{2C}—V_{nC} are the Fourier component amplitudes of the column frequencies
- V_{IMD} is the sum of all intermodulation components.

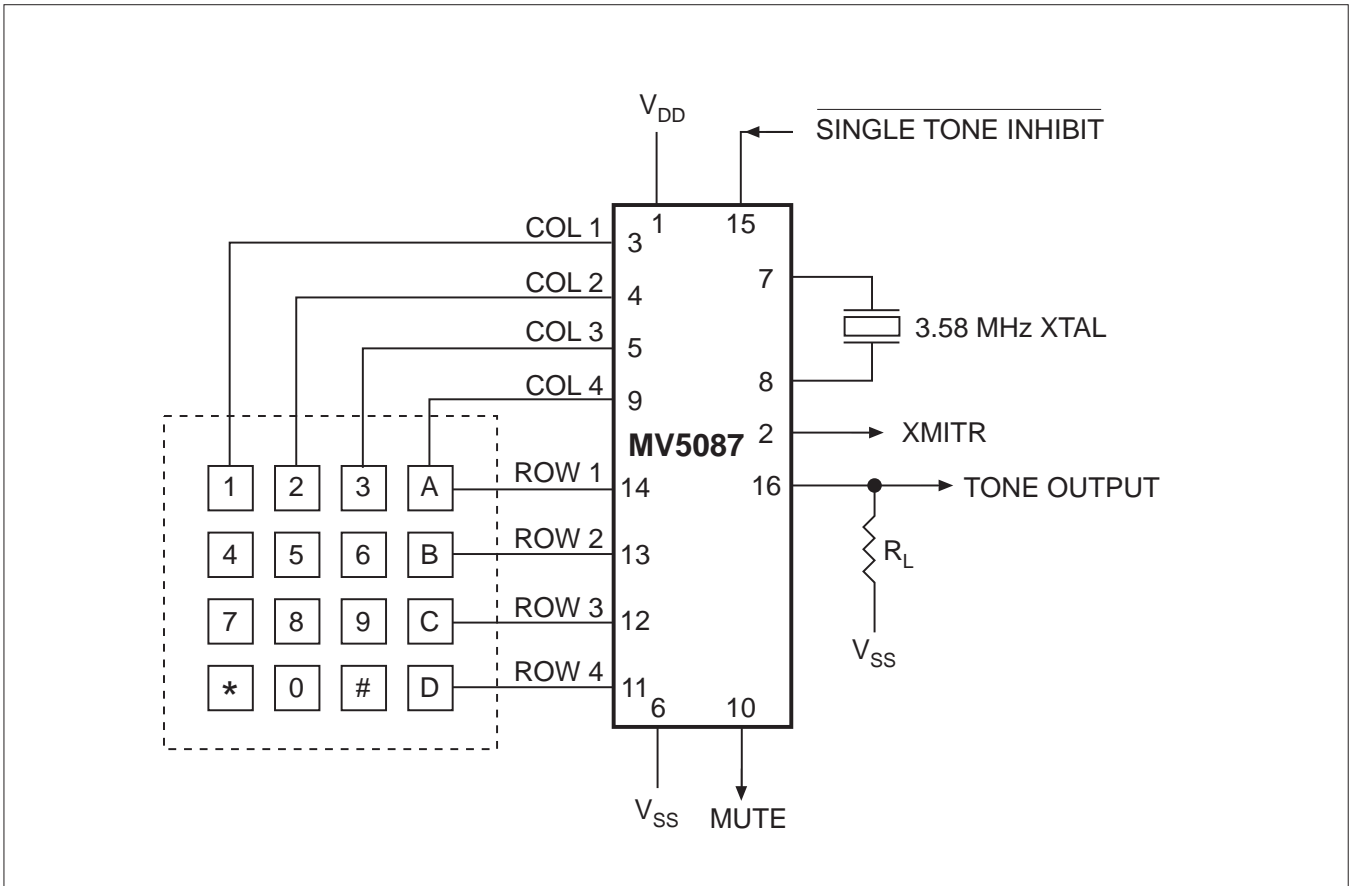

Figure 7: Connection diagram